

INSTALLATION GUIDE

Trex[®] w/ Horizons[™]

HORIZONTAL FENCE SYSTEM



For current installation instructions, download guide:

[TrexFencingFDS.com](https://www.TrexFencingFDS.com)

Plan Your Fence

Sample Fence Sketch and Measurements

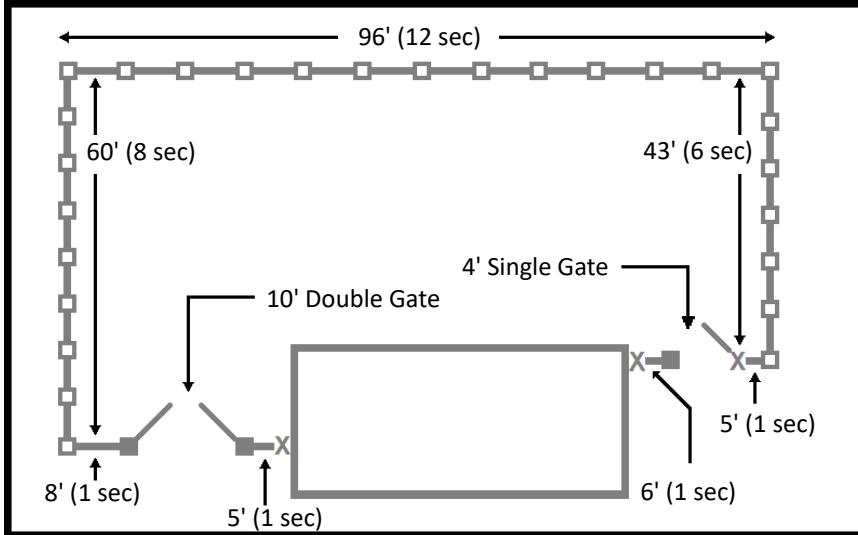

>> Figure the number of sections for each line by dividing the length of each line in inches, then that amount by 97. Round up any remainder. For example:

$$45 \text{ ft} = 540 \text{ in} / 97 = 5.56, \text{ (round up to 6 sections)}$$

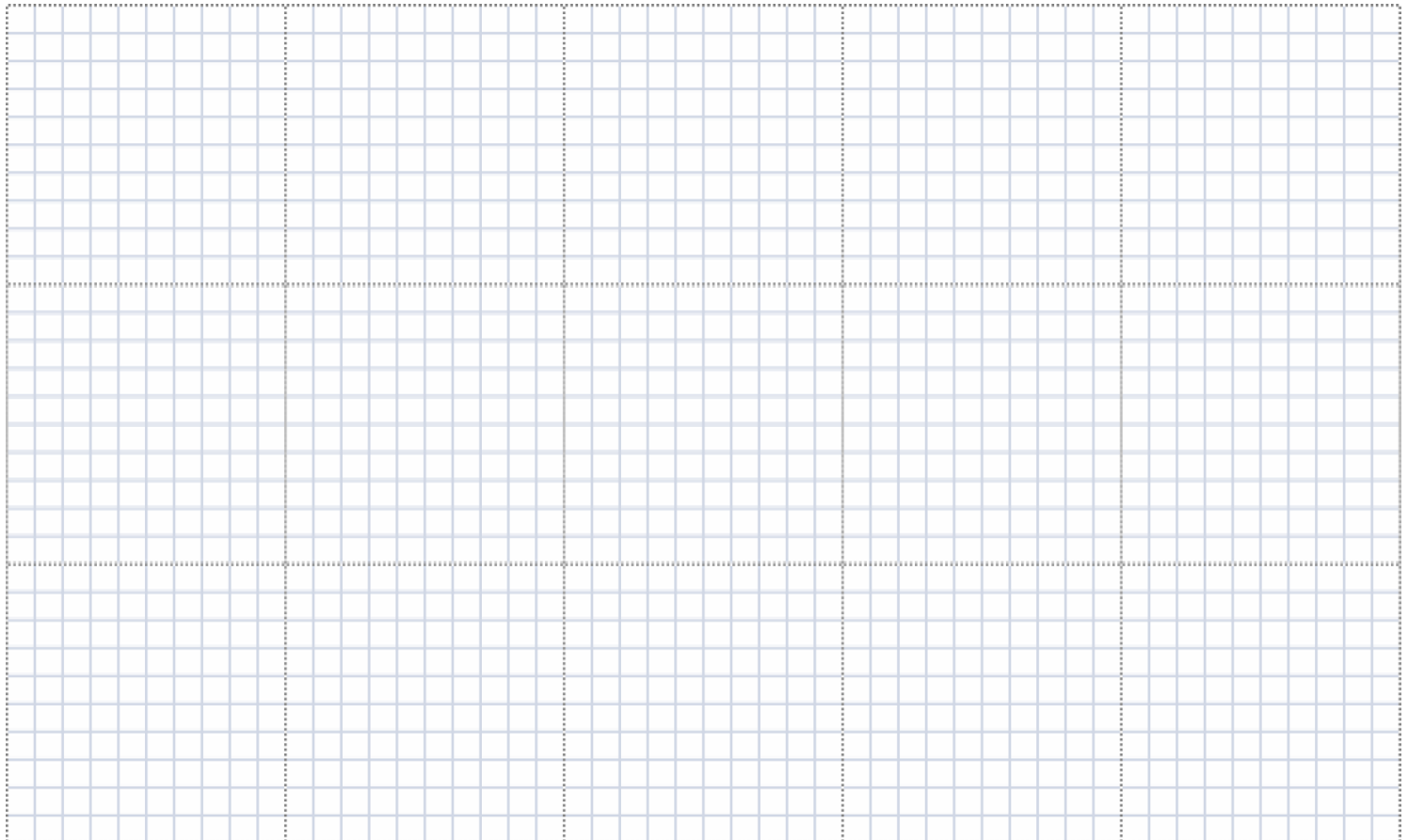

Calculate Materials

The materials calculations on this form are intended for rough estimation based on 6' tall x 8' wide sections. Verify all counts.

# of Sections (Divide each line by 97" and round up; add total # of sections):			# of Terminal Posts	
Items Needed (6' H x 8' W Section)		Multiplier	Total Materials For Sections	
Material	Quantity			
6' Horizons Frame Kit	1	x (# of sections)		
8' Trex Pickets	15	x (# of sections)		
9' Trex Posts	1	x (# of sections + # of terminal posts)		
Trex Post Caps	1	x (# of posts)		
80' lbs Bag Concrete	2	x (# of posts)		
Steel Post Insert	based on # of hinge posts			
# of Single Gate(s)		# of Single Gate Hardware Package(s)		
# of Double Gate(s)		# of Double Gate Hardware Package(s)		

* For standard single gates (46 1/4" opening) : (1) small Trex gate panel, (1) steel post insert, and (1) Trex single gate hardware kit.

* For standard double gates (130 3/4" opening) : (2) large Trex gate panels, (2) steel gate post inserts, and (1) Trex double gate hardware kit.

Note: Horizons frames and fasteners are made of powder-coated stainless steel and aluminum components. To reduce corrosion, avoid installing within 5 miles of a body of salt water or in contact with the ground (adapt the bottom rail if necessary as described on page 12, 7B).

Tools Needed

- | | |
|---|---|
| <input type="checkbox"/> Stakes | <input type="checkbox"/> Circular Saw |
| <input type="checkbox"/> String Line | <input type="checkbox"/> Drill |
| <input type="checkbox"/> Marking Paint | <input type="checkbox"/> Pencil |
| <input type="checkbox"/> Hammer | <input type="checkbox"/> Wheelbarrow |
| <input type="checkbox"/> Tape Measure | <input type="checkbox"/> 4' Level |
| <input type="checkbox"/> Shovel | <input type="checkbox"/> Speed Square |
| <input type="checkbox"/> Post Hole Digger | <input type="checkbox"/> Finish Nail gun (optional) |
| <input type="checkbox"/> Digging Bar | |

Before you begin

- Confirm location of underground utilities with local providers before you dig.
- Check local zoning laws and HOA rules which may regulate the height and placement of your fence.
- Apply for local permits as directed by local codes.
- Wear proper safety protection for eyes and ears.
- For a step-by-step installation video, visit:

<https://TrexFencingFDS.com/videos>

Exploded View

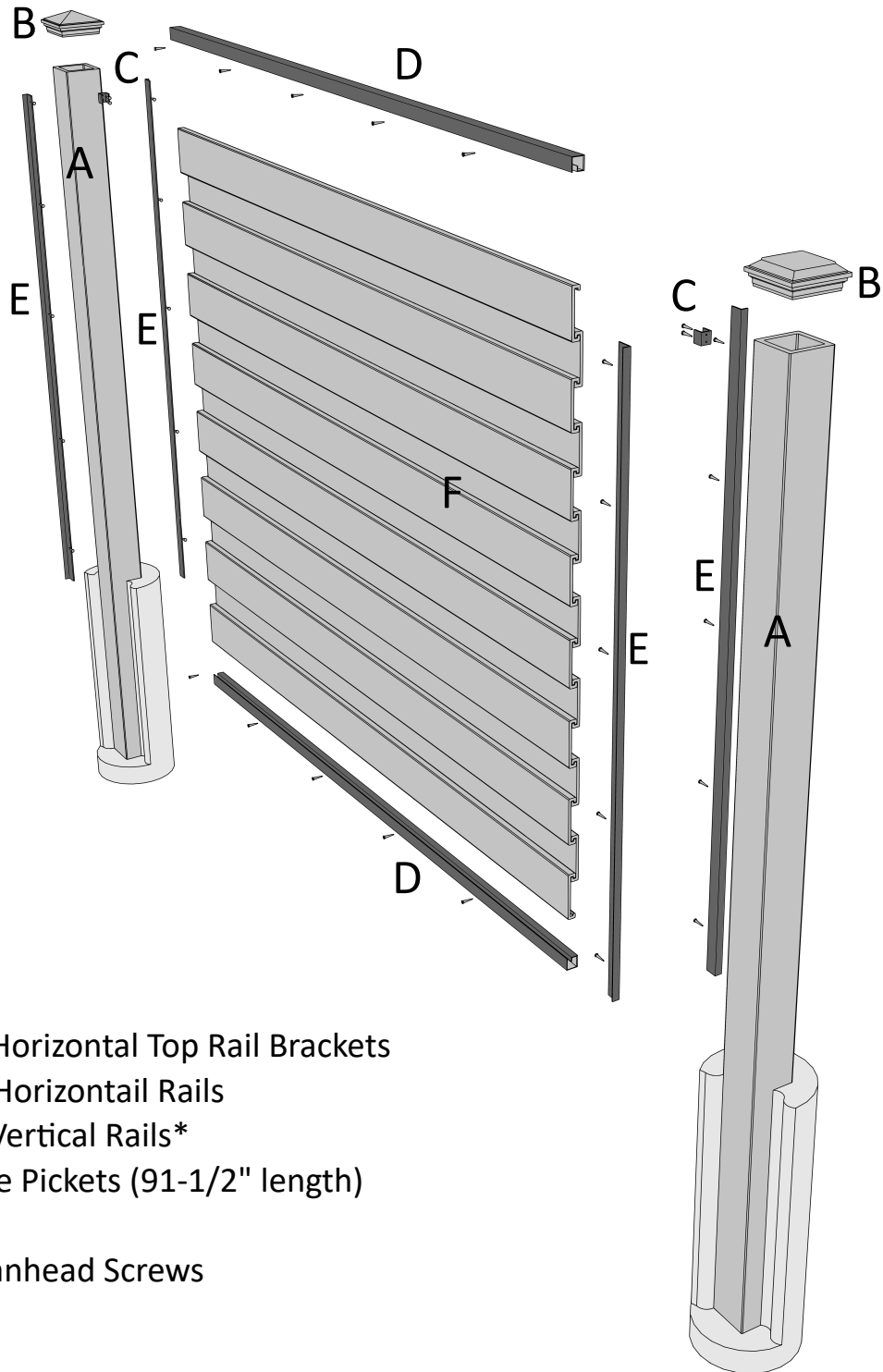

- A. 1 - Trex[®] Post
- B. 1 - Post Cap
- C. 2 - Horizons[™] Horizontal Top Rail Brackets
- D. 2 - Horizons[™] Horizontal Tail Rails
- E. 4 - Horizons[™] Vertical Rails*
- F. 15 - Trex[®] Fence Pickets (91-1/2" length)

43 - #10 x 3/4" Panhead Screws

*1 - Optional midrail

Trex[®] is a federally registered trademark of Trex Company, Inc., Winchester, Virginia.

Horizons[™] Horizontal Fence System is a trademark of Fencing Supply Group. US Patent No. 97/918,15

Step 1: Understanding the Install Method

Horizons is designed to be built on level ground. If Horizons is built on a slope it will be necessary to step the panels as shown below. This may leave gaps under the fence and may also require longer posts to accommodate the steps.

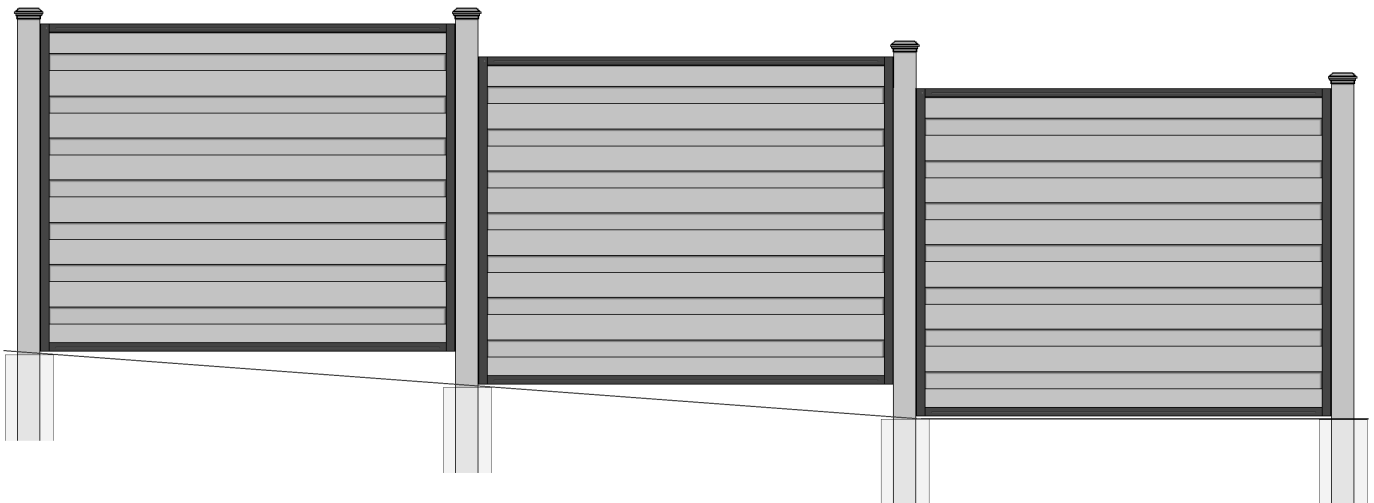

Step 2: Stake and String

1. Stake and string fence lines. Drive stakes approximately 2 ft. beyond property pins so stakes will not be disturbed when digging holes, and set line approximately 4-5 inches inside of property lines to ensure no encroachment on neighbors.
2. Mark location of posts. Spray paint a line perpendicular to the string every 97" on center. Ideal spacing *between* posts is 92". If sections are shorter, horizontal rails and pickets will need to be cut for length. Spray additional lines (making a cross) 2" in from the string to mark the center of the hole (see Fig. 1).

Note: Post layout should not exceed 97" from center of post to center of next post or rails will be too short. Laying out posts 97" on center may leave a remainder at the end of a line. Set all sections per line at 97" on center and split the remainder for the last two sections (see Fig. 1A). Alternatively, for a uniform look, fence lines may be divided into even sections, each less than 97" on center. Ex.: If fence line is 68 ft. long, space posts 90.7" on center ($68' \times 12" = 816" / 9 \text{ sec} = 90.7"$).

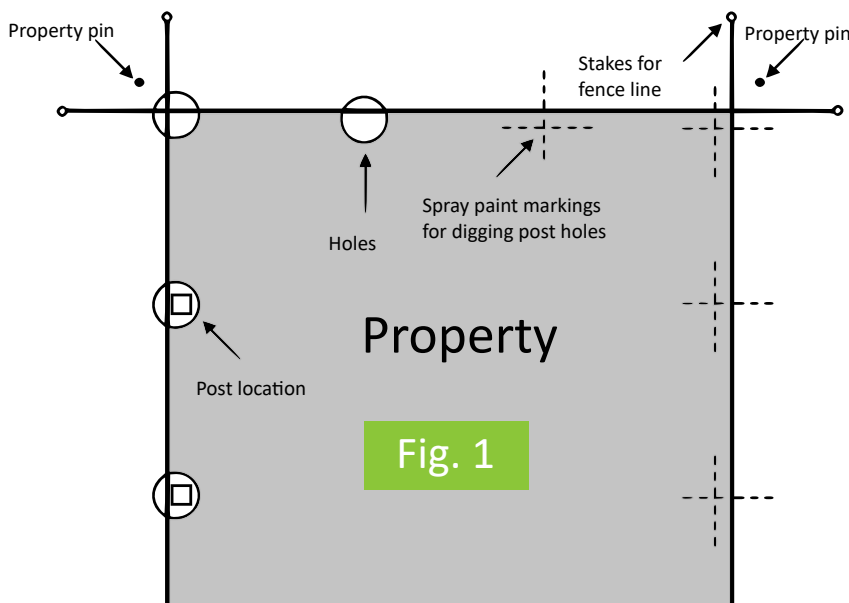
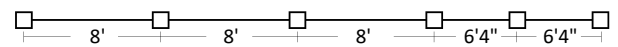

Fig. 1A



Example

Step 3: Dig Holes

1. Dig holes for the posts making sure not to disturb the stakes for the string. The string may be removed and replaced after holes are dug. The holes should be approximately 12" in diameter and 30" deep (depending on local codes). Holes should be dug so they allow equal amounts of concrete on all sides of posts (see Fig. 2.).

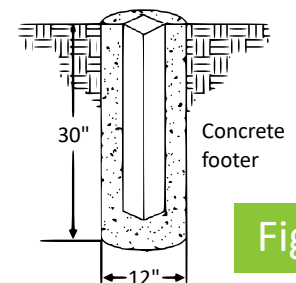
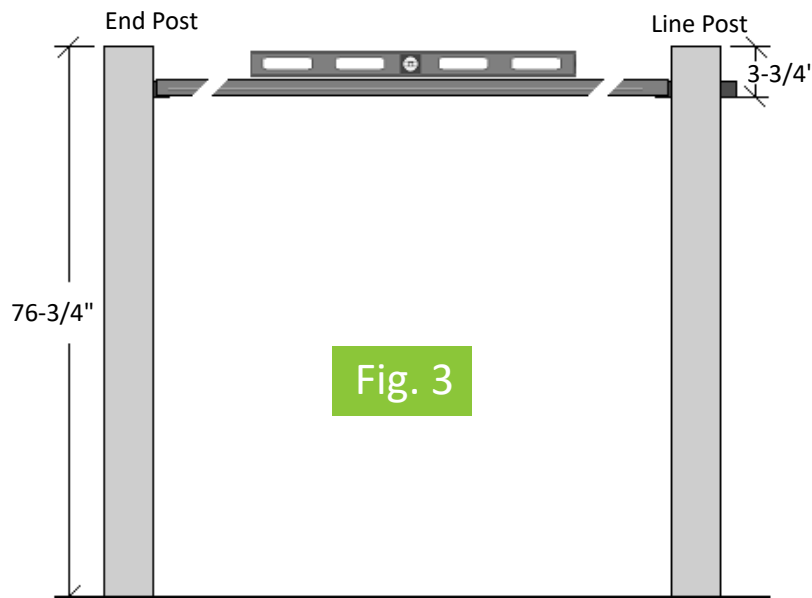

Fig. 2

Step 4A: Set Posts on Level Ground

If posts will be set on sloping or uneven ground, or will be stepping, skip to Step 4B.

1. Attach a horizontal top rail bracket using two screws (3-3/4" below the top of each post). End posts will only have one bracket (which faces the fence section). Line posts will have brackets attached on two sides (see Fig. 3).
2. Set the first post in the hole. Plumb and level the post to the string line (ensure the post is 76-3/4" high*) and fill the hole around the post with concrete mix.
3. Place post in the next hole. Place a horizontal rail onto the brackets. Use a level on the rail and raise or lower the post until it is level with the previous post. This rail will ensure that your posts are spaced correctly (see Fig. 3). Plumb and level the post to the string line and fill the hole around the post with concrete mix.
4. Continue this process until all posts are set.



* Measurements for additional heights are available online:
<https://trexfencingfds.com/resources/horizons-drawings/>

Step 4B: Set Posts on a Slope

1. Attach a horizontal top rail bracket 3-3/4" below the top of the post to one side of each post using two screws (see Fig.4).
2. Set the uphill post first. This post should be set at 74-1/2" tall with the bracket facing to the next post down hill. Plumb and level the post to the string line. Fill the hole around the post with concrete mix (see Fig. 4).
3. Place the next downhill post in its hole with the bracket facing uphill toward the last post that you set. Place a horizontal rail onto the brackets of the two posts and place a level on the rail. Adjust the post height of the downhill post until the rail is level (see Fig. 5). This will also ensure that posts are spaced correctly. Plumb and level the post and fill the hole around the post with concrete mix.

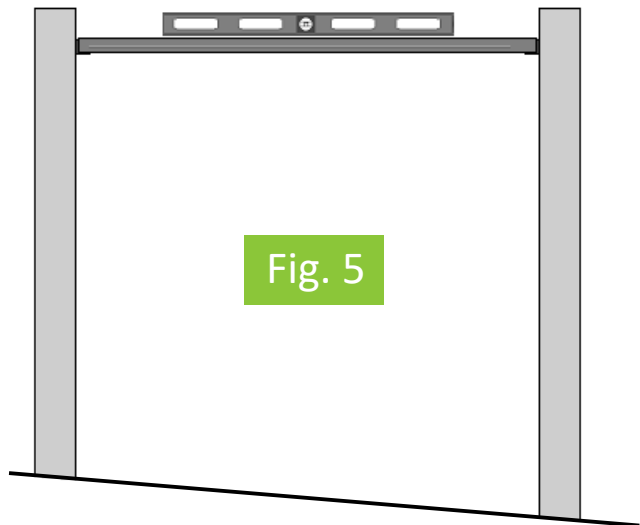
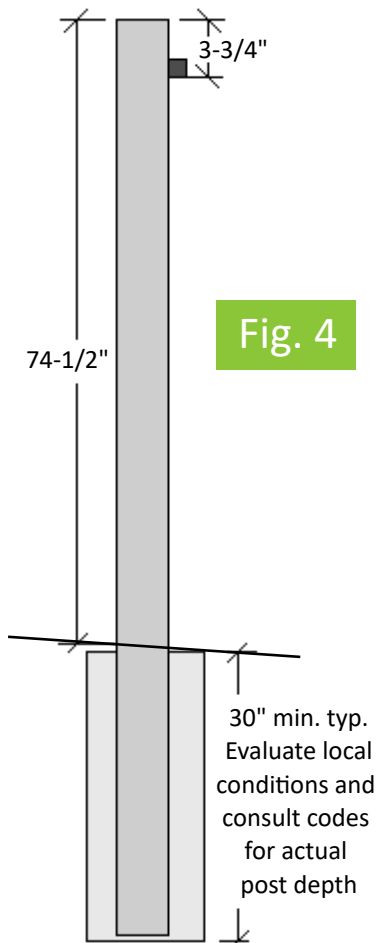

- Attach a horizontal top rail bracket to the downhill side of the post. To determine the location of this bracket, measure from the horizontal rail to the ground on the uphill side of the post: (A) subtract this from the height of the rail on the first post; (B) Add this measurement to 3-3/4" (the measurement of the first bracket) and this will be the placement of the downhill bracket (see Fig. 6).

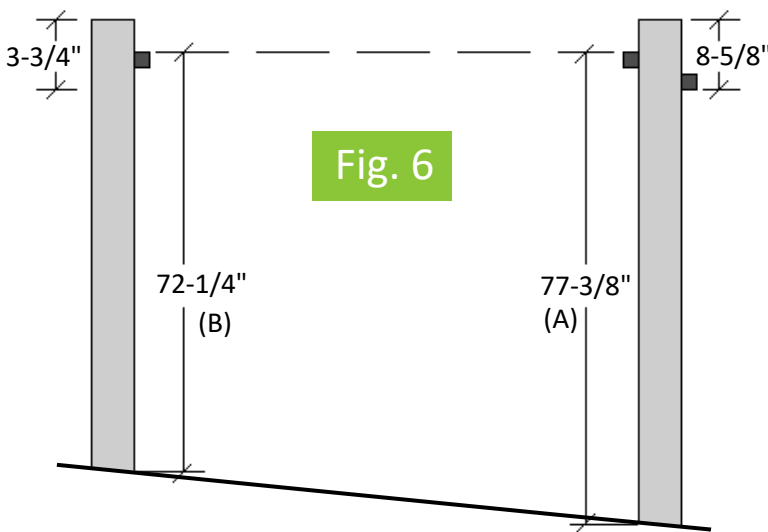

Downhill Bracket
Placement

Example:

Rail Height (A) = 77-3/8"

Rail Height (B) = $\frac{-72-1/4''}{5-1/8''}$

Upper Bracket $\frac{+3-3/4''}{\text{Measurement}}$

Downhill Bracket $\frac{8-5/8''}{\text{Placement}}$

- Repeat steps 3 and 4 until all posts are set.

Step 5: Cut Horizontal Rails

- If you have sections that are shorter than 92" between posts, you will need to cut the horizontal rails for length. Measure between the posts and cut the rails using a metal cutting blade. Be sure to cut only one end of the rails (see Fig. 7). Touch up the cut end using a zinc rich primer and a matching topcoat to help prevent rust.

Fig. 7



- Place a horizontal rail over the brackets with the screw holes facing you. If the rail has been cut, you will need to slide the cut end over one bracket first and then drop the other end over the other bracket (see Fig. 8).

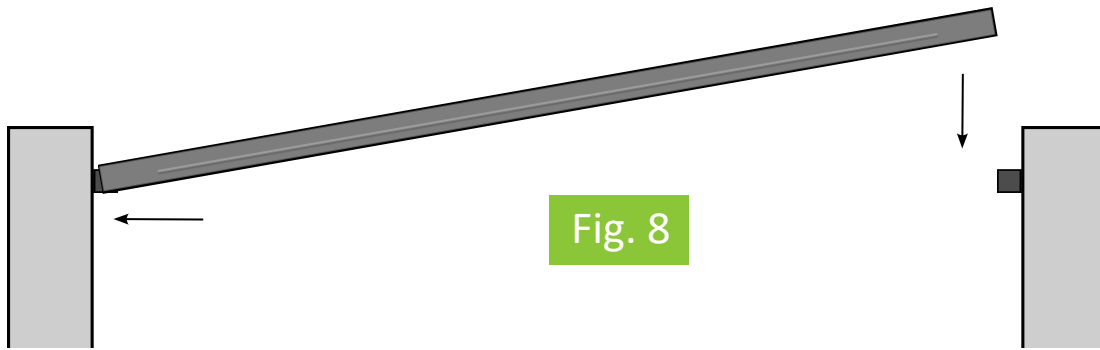

Step 6: Attach Vertical Back Rails

- On the back side of the fence, attach a vertical rail to the post on the exterior of the horizontal rail. Repeat on the opposite post. The shorter leg of the angle should be placed flat against the post and the top of the vertical rail should be flush with the top horizontal rail (see Fig. 9). The screw holes on the horizontal rail should be on the side opposite the vertical rail. Attach the rails to the posts using the provided screws (see Fig. 10).

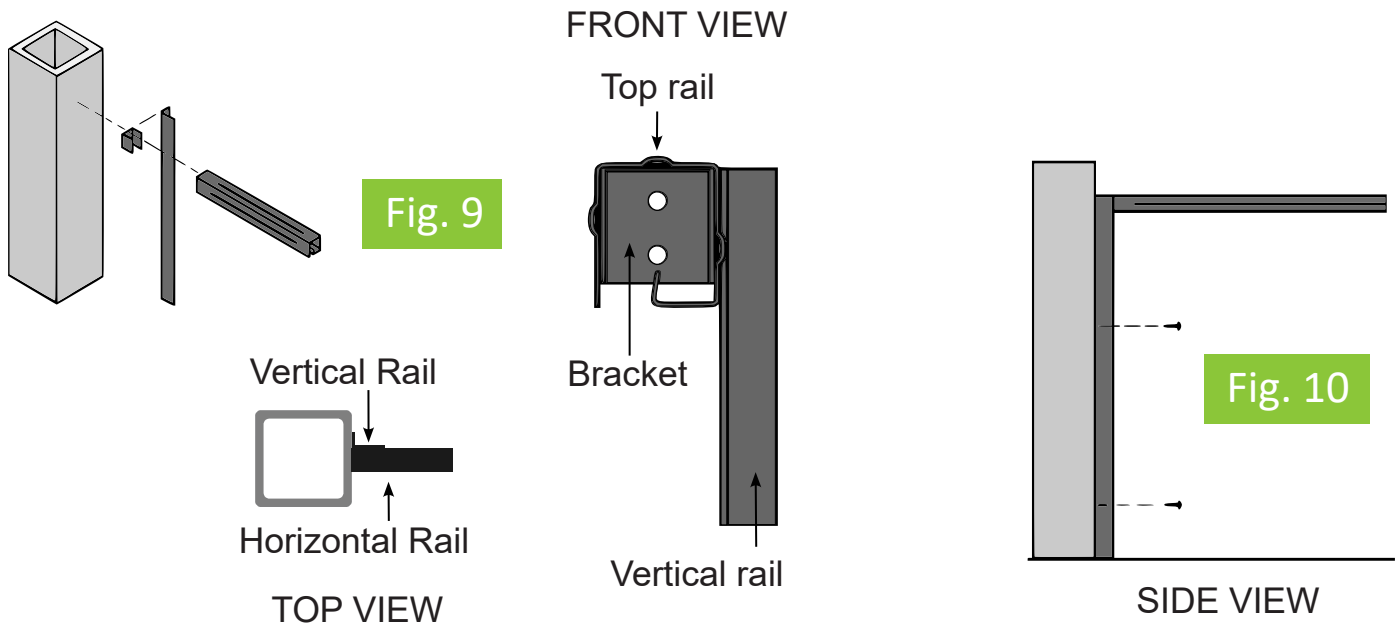

Step 7A: Notch and Hang Top Picket

1. Make a 1" notch on each end of the first picket as shown below (see Fig. 11). If necessary, cut pickets for length. Pickets should be $\frac{3}{8}$ " shorter than the opening between vertical rails to allow for expansion.
2. Remove the horizontal rail and slide the picket onto the rail with the notches facing upwards (see Fig. 11). With picket in place, drop the rail back over the brackets, being sure to face the picket knuckles toward the vertical back rail (see Fig. 12).



Fig. 11

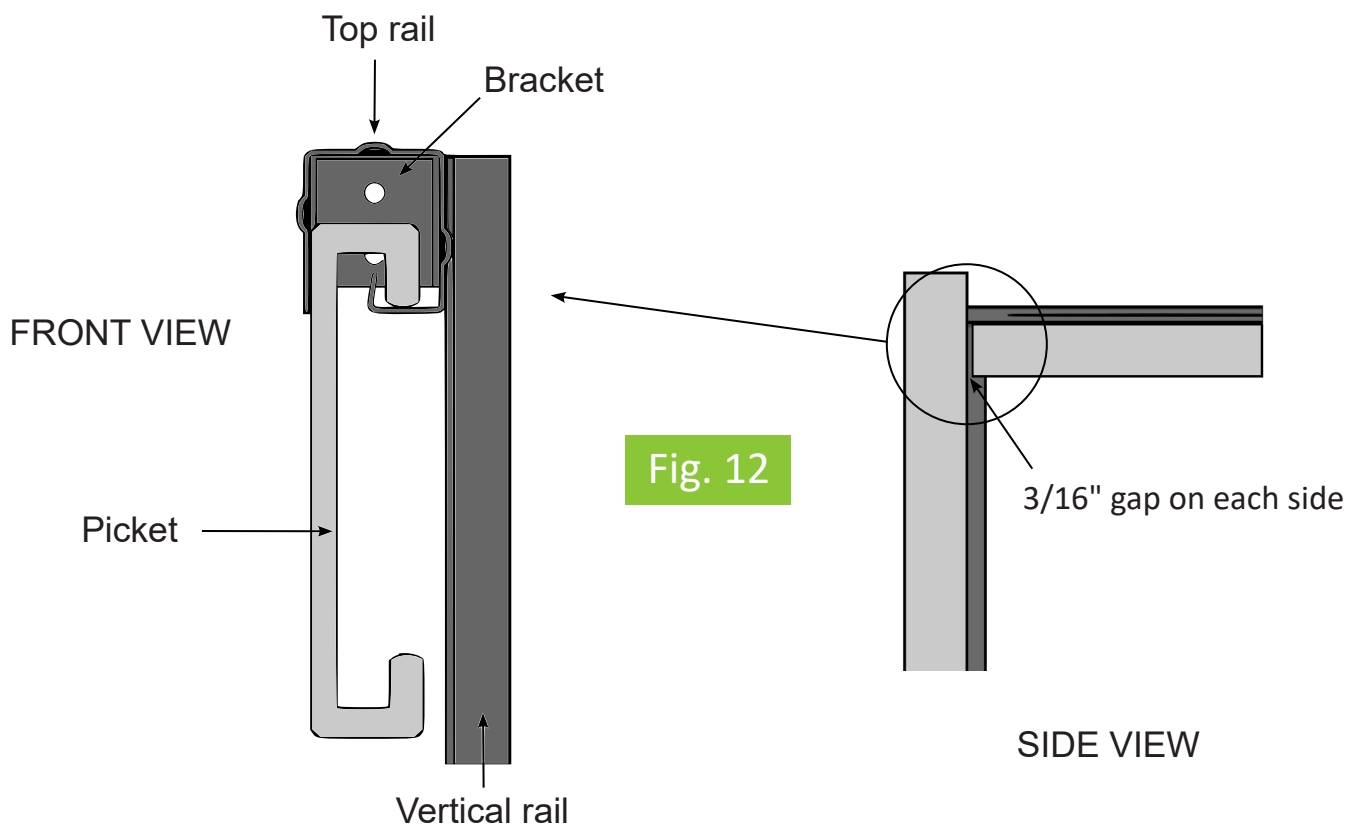
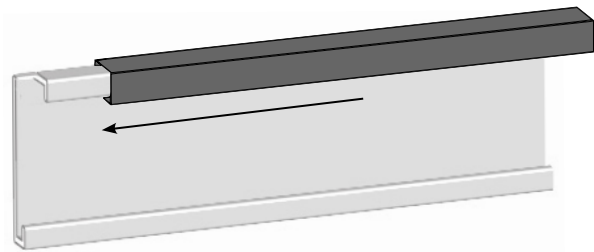
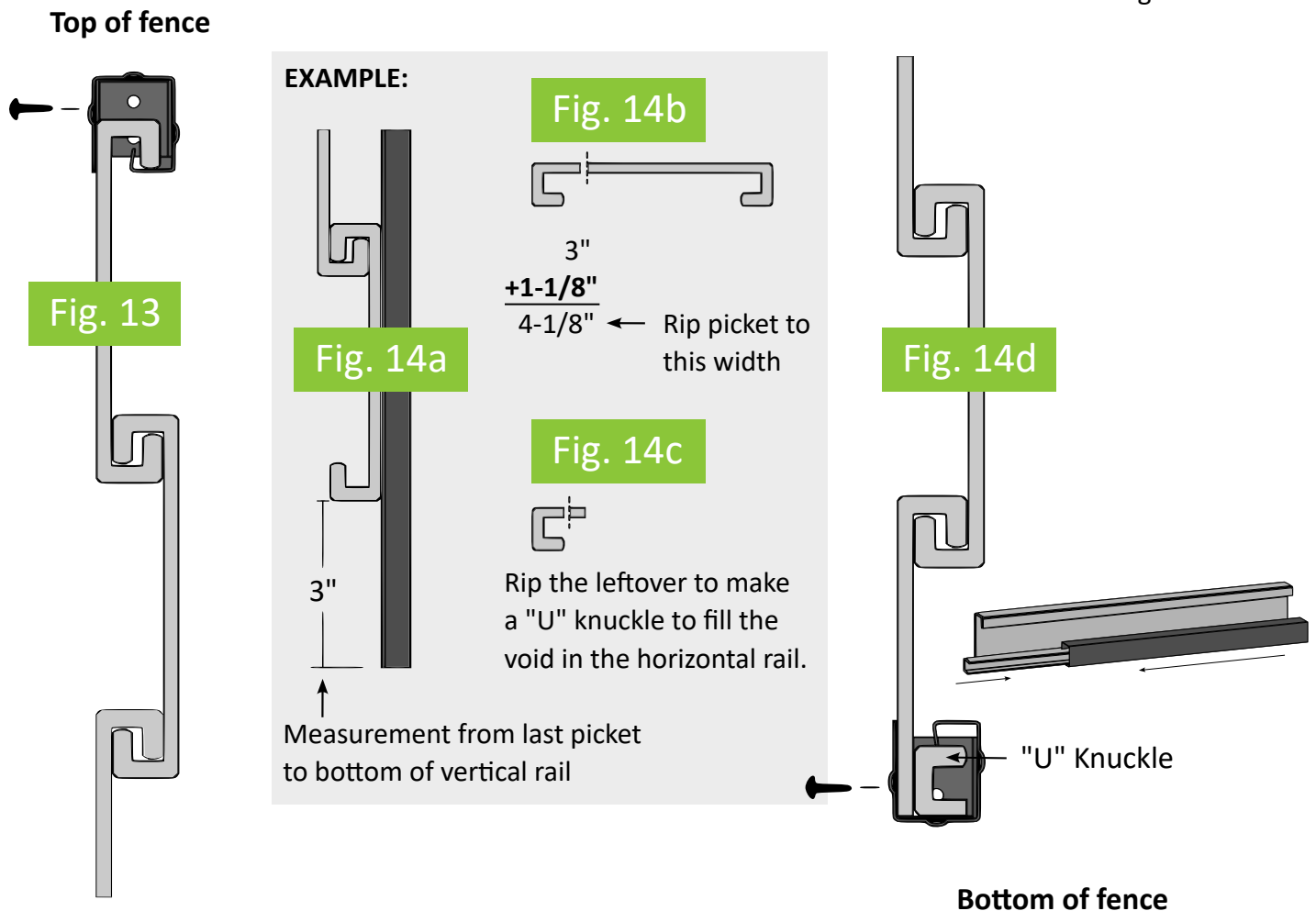

Fig. 12

Step 7B: Hang The Pickets

1. Hang the remaining 14 pickets from the top picket by interlocking them to each other (see Fig. 13). Due to color variations that may be present, we recommend installing similar color pickets together within the same section of fence.
2. With the next to the last picket installed, measure from the bottom of this picket to the bottom of the vertical rail (Fig. 14a). Rip the last picket 1-1/8" wider than this measurement (Fig. 14b). Rip the knuckle off the leftover piece of this picket to create a "U" knuckle (Fig. 14c). Fit the horizontal rail onto the cut end of the last picket and slide the leftover "U" between the cut picket and the knuckle of the horizontal rail as shown in Fig. 14d. Screw the picket and the "U" to the horizontal rail through the holes provided and hang the last picket in place.

Tip: Adjust measurements as needed to ensure bottom rail is not in contact with ground.



Step 8: Attach Vertical Rails

1. Attach vertical rails to the post on each end, opposite the vertical rail on the other side. The shorter leg of the angle should lay flat against the post and the larger leg should be pushed tightly against the pickets. Hold it flush against the top of the top rail and attach the vertical front rails to the posts (see Fig. 15).

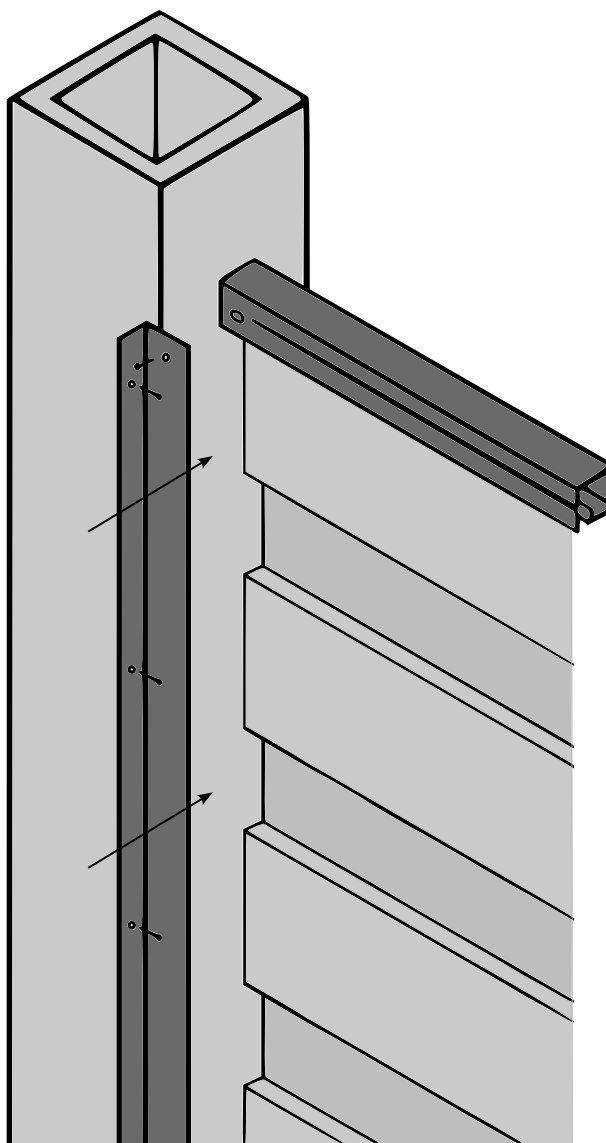
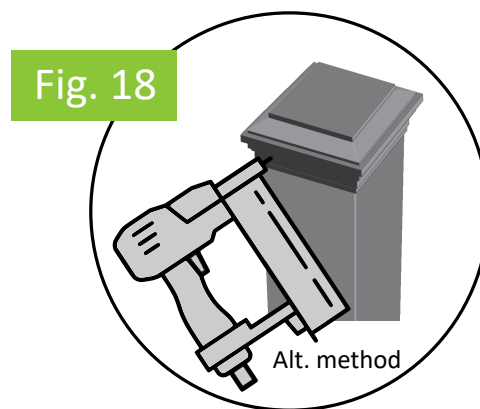
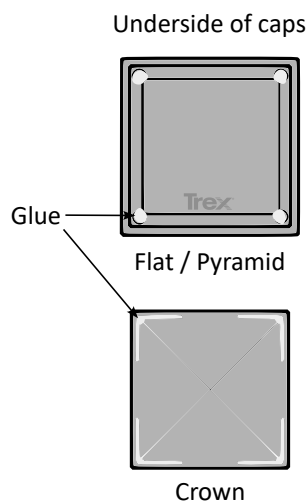

Fig. 15

Step 9: Secure Vertical Rails to Horizontal Rails

1. Secure the vertical rails to the horizontal rails using the provided screws in each corner on both front and back sides (see Fig. 17). If no holes exist where the rails are to be secured, pre-drill each hole using a 3/16" drill bit. This hole should line up with the slot on the horizontal rails. If the rail has been cut for length and a new slot is necessary, the horizontal rail will need to have a 5/32" hole drilled to line up with the hole in the vertical rail.
2. Place post caps onto posts and secure using E6000 glue or finish nails (see Fig. 18).



Step 10 (Optional): Install Vertical Mid Rail

NOTE: If installing Horizons in a high heat or high humidity area, use an additional vertical rail in the center of the fence panel to reduce the risk of warping boards.

1. Mark the center of the section of each fence panel.
2. Mark and drill holes for screw placement. Hold the vertical mid rail in position with the wider leg of the L-channel against the fence and mark the location of each hole needed to attach the mid rail. The hole should be marked on the top side of each picket so that the screw will connect to the knuckle of both interlocking pickets. Additional holes should be marked at each end of the rail to attach the mid rail to the top and bottom horizontal rails. See Fig 19.
3. Using a 3/16" drill bit, drill a hole in the vertical mid rail at each mark.
4. Hold the mid rail to the center of each fence panel, making sure it is flush with the top of the horizontal rail and place a screw into the top hole to attach the rail to the top picket. Level the vertical rail and attach another screw into the bottom picket. Place screws into the remaining holes and attach the rail to the remaining pickets. Using a 5/32" drill bit, drill a hole into the top and bottom horizontal rails by placing the bit through the hole of the top and bottom of the vertical mid rail which was previously drilled in Step 2. Finish by placing a screw into these holes.

